



User's Manual

African Swine Fever Virus Antigen One-Step

*For the detection of ASFV antigen in EDTA
blood, EDTA lymph node fluid or sera
samples*

REF P1002-AG02

Σ 6

January 2022

Please use only the valid version of the package insert provided with the kit.

1. Table of Contents

1.	Table of Contents	2
2.	Introduction.....	3
3.	Intended use of the test kit	3
4.	Principle of the test kit	4
5.	Contents	4
6.	Handling and storage of specimens	4
7.	Sample material.....	4
8.	Precautions.....	4
9.	Test protocol	5
10.	Validation of the test.....	5
11.	Interpretation of the test results.....	6
12.	Symbols used with EVL ASSAYS	7

2. Introduction

ASFV is a viral disease infecting all members of the Suidae family (African bush pig, warthog, wild boar and domestic pigs).

First report is from 1921 where it was first reported in Kenya. The virus is transmitted by direct contact or soft ticks of the Ornithodoros genus or indirectly by movement of infected animals, improper disposal of contaminated animal products.

The most recent introduction in 2007 is of origin in Eastern Africa and started in Georgia (Poti harbour) from where it spread to Caucasus and Russian Federation to reach the eastern border of the European Union in early 2014.

On the other side from Russia it reached Chinese borders in 2017 from where it was spread through China (end of 2018).

The expansion of the disease is a serious threat to the pig industry in central and western European countries and Asia. In spite of this increased threatening situation and many efforts, no effective vaccine has been developed to-date.

ASFV belongs to the family of Asfarviridae, the DNA of this family is based on a double-strand DNA genome which can be up to 170-190 kbp and might contain over 150 ORFs. The fact that ASFV can replicate in swine as well as in its arthropod vector may contribute to the complexity of ASFV protein expression.

The ASFV virion is built of 54 structural proteins. The virus replicates in macrophages and monocytes and induces a host immune response characterized by the lack of neutralizing antibodies. Acute infections can be detected by the circulation of VP72 or VP30. Acute infections are associated with decreased numbers of circulating macrophages, monocytes, lymphocytes and neutrophils, in late-phase coagulation develops and leads to characteristic haemorrhagic syndrome.

One of the main striking aspects of ASFV infection is the fact that virus-specific antibodies, even those from recovered or chronically infected pigs, or those found in ASFV-resistant animal species inoculated with the virus, do not neutralize the virus.

The virulence of strains differs, high virulent strains induce high fever, this causes loss of appetite and their condition worsens. The skin usually becomes whiter. Reddening of the ears and legs is usually seen. Groups of pigs huddled together, breathing increases to abnormal, they become unsteady on their legs also abortions will be seen.

Raw meat and dry meat will still harbour the virus and can be infectious to other pigs.

3. Intended use of the test kit

This One-Step test is intended to be used as a practical/routine screening test that can be done in a few minutes. This test kit is designed to detect ASFV antigen by use of a rapid immunochromatographic assay.

4. Principle of the test kit

The ASFV antigen One-Step is based on a chromatographic principle in which a monoclonal antibody reacts with epitopes of the ASFV virus antigen. A monoclonal antibody is conjugated to colloidal gold particles and a monoclonal antibody is immobilized on the test strip in the test zone “T”.

ASFV antigen in the sample that is applied to the test strip at the sample zone “S” will bind to the colloidal gold particles which then migrate to zone “T”. A colour change in zone “T” indicates a positive test. Labelled colloidal gold particles are also immobilized on the test strip in the control zone “C”, to indicate that the test is working properly.

5. Contents

- 6 x Pouches, each containing 1 test strip and 1 pipette
- 6 x Buffer vial
- 1 x Protocol

6. Handling and storage of specimens

The One-Step should be stored at room temperature ($\pm 21^{\circ}\text{C}$). An unopened package can be used until the expiry date. An opened package must be used immediately. If the conditions are no longer fulfilled the test can no longer be used. Avoid freezing and heating as this will contribute to destruction of the test. Samples may be used fresh or may be kept frozen below -20°C before use.

7. Sample material

It is advised to test fresh samples for the best result.

8. Precautions

- Handle all biologicals materials as though capable of transmitting infectious diseases.
- Do not pipette by mouth
- Do not eat, drink, smoke, prepare foods or apply cosmetics within the designated work area.
- Do not use components which passed the expiry date and do not mix components from different serials lots together.
- Optimal results will be obtained by strict adherence to this protocol. Careful pipetting and sampling throughout this procedure are necessary to maintain precision and accuracy.
- Each test strip is ultimately used as an optical reference. Therefore, do not touch the surface of the test strip and protect it from damage and dirt.

9. Test protocol

1. Unpack the test strip, swab and pipette. Only open the amount of pouches to be used. An opened package should be used immediately.
2. Add **3 drops** of EDTA blood, lymph node fluid or sera to the buffer vial (Figure 1).
3. Mix well by using the pipette (Figure 2).
4. Add **4 drops** of the buffer vial containing the sample, with the included pipette **slowly** to the sample zone "S" (Figure 3).
5. Read the result after 15 – 20 minutes (for the interpretation of the test result see chapter 10 and chapter 11).



Figure 1



Figure 2

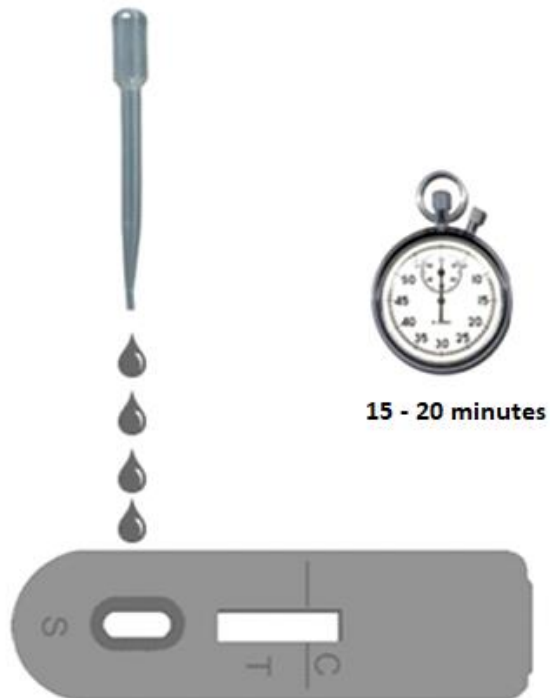

Figure 3

10. Validation of the test

To validate an EVL One-Step a control line should always be visible at control zone "C". If no control line is visible the test should be considered invalid.

Results should be read in the given time. Results read after the given time should be considered invalid. Invalid tests should be repeated with a new test.

11. Interpretation of the test results

Positive:

Two lines are visible, in zone “T” and in zone “C” (Figure 1) The sample contains ASFV antigen. Positive results may vary in optical density due to variation in viral concentrations in the sample.

Weak positive:

Two lines are visible, a weak line in zone “T” and a line in zone “C” (Figure B). The sample contains low concentrations ASFV antigen.

Negative:

One line is visible in zone “C” (Figure C). The sample does not contain ASFV antigen.

Not valid:

No line is visible in zone “C” (figure D). Repeat the test procedure.

Important:

A positive result should be confirmed by PCR, or virus isolation for subtypes. Diseased, but negative tested animals should be retested within 2-3 weeks.

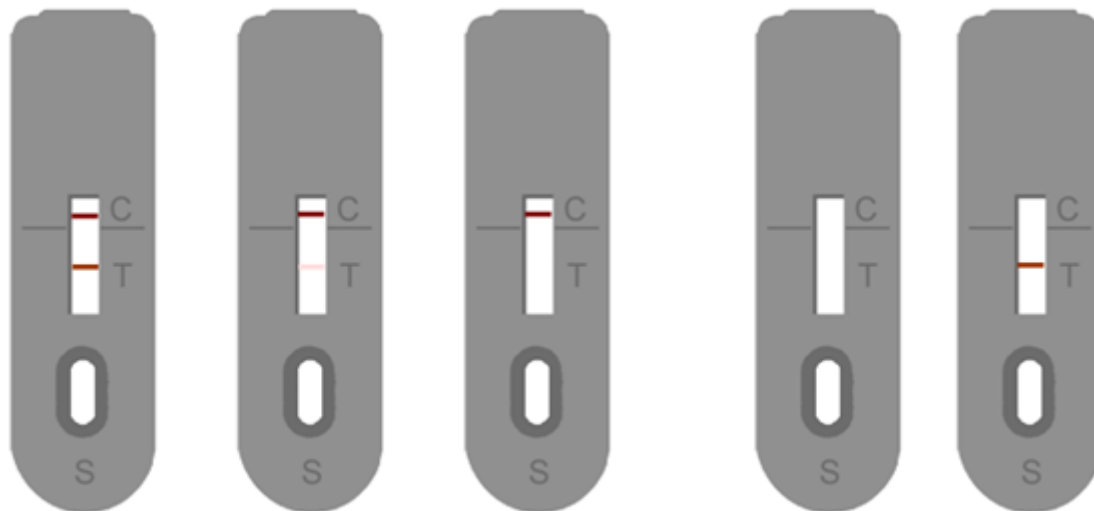

**Figure A:
Positive**











**Figure B:
Weak positive**

**Figure C:
Negative**

**Figure D:
Not Valid**



12. Symbols used with EVL ASSAYS

<u>Symbol</u>	<u>English</u>
	Consult instructions for use
	European Conformity
	In vitro diagnostic device
	For research use only
	Catalogue number
	Lot/ No. / Batch code
	Contains sufficient for <n> tests
	Storage Temperature
	Expiration Date
	Legal Manufacturer
Distributed by	Distributor
Content	Content
Volume/No.	Volume / No.

The entire risk as to the performance of these products is assumed by the purchaser. EVL shall not be liable for indirect, special or consequential damages of any kind resulting from use of the products. In case of problems or questions contact EVL.